

Completely install the sliders one side at a time. Never loosen both motor mount bolts at the same time or your engine may shift and you will potentially have to jack it back into place to ensure proper alignment.

WARNING: Since motor mount bolts are fine thread steel bolts, it is easy to cross thread them and damage the threads. Always start the first few turns by hand before using the ratchet on the bolt. We recommend using a small amount of anti-seize paste on the supplied bolts.



Recommended torque – If dry torque to 32 ft-lbs. If lubricated torque to 25 ft-lbs.

2) Attach the right side slider base to the forward most engine mount using the 10 x 90mm bolt provided on the 50-0660RL base, threading this assembly in place of your OEM motor mount bolt.

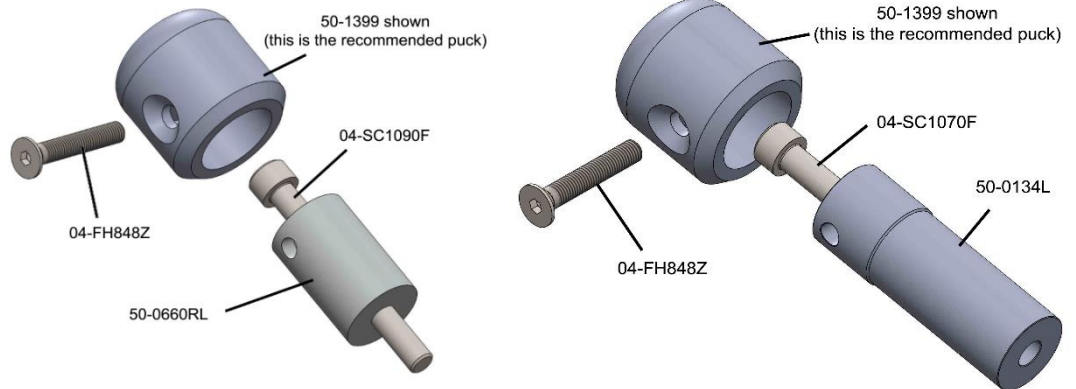

3) Attach the left slider base 50-0134L using the 10x70mm bolt.

4) Slide the plastic slider puck over the top of the base and secure it in place using the 8 mm countersunk bolt provided. The bolt passes first through the non-threaded hole and then screws into the threaded hole on the opposite side of the base. The plastic is slightly undersized on the far side of the puck to act as a locknut for the bolt.

Note: if you select the 50-1599 pucks you will need to trim the bodywork. We suggest tracing the area to be trimmed and using a dremel tool with a drum sanding attachment.

Woodcraft Technologies
105 Baldwinville Rd. Winchendon, MA 01475
978-297-2977

WARNING: Improper installation and/or failure to comply with all warnings and instructions may cause a loss of control and serious injury or death. The motorcycle should be run and thoroughly inspected before use. DO NOT INSTALL OR USE THIS PRODUCT IF YOU ARE UNABLE TO DO SO IN COMPLIANCE WITH ALL INSTRUCTIONS AND WARNINGS. SEEK THE ASSISTANCE OF A TRAINED PROFESSIONAL TECHNICIAN.